

Advanced Movable Charging Station

Shreyas Gavade, Shreyash Bhujbal, Vivek Kamble, Rushikesh Attigiri, Sainath Dafale, Mrs. B. K.Jagtap

Department of Electronics and Computer Engineering

Sharad Institute of technology College of Engineering

Abstract

This project presents an Advance Movable Electric Vehicle (EV) Charging Station powered by a solar photovoltaic (PV) system to reduce grid dependency and promote renewable energy use. The system uses an ARDUINO-based controller integrated with RFID, GSM, and GPS modules for smart monitoring and user authentication. A SEPIC converter is employed to maintain a stable DC output across varying solar inputs, ensuring efficient battery charging. The design is simulated in Proteus software and a 5W hardware prototype is developed and tested, demonstrating reliable and portable EV charging performance..

The rise of electric vehicles (EVs) signals a promising shift towards sustainable transportation,

offering a solution to combat climate change and reduce reliance on fossil fuels. However, challenges persist in the charging infrastructure, with conventional stationary charging stations causing significant waiting times for vehicle owners. This hinders the seamless integration of EVs into mainstream transportation systems. To address this issue, our project aims to develop an innovative solution: the Solar Wireless Charging System in Electric Vehicles. By harnessing

Keywords

Portable EV Charger

Mobile Charging Station

DC Fast Charging (DCFC)

On-the-go Charging

Off-grid Charging Solution

Emergency EV Charging

High-power Mobile Charging

Advanced and Technological Keywords

IoT Connectivity (Internet of Things)

Smart Charging

App-based Control/Monitoring

Introduction

Ever increasing effect of greenhouse gases from the conventional engine lead to the environmental concern. This paved to the booming of pollution free Electric Vehicles (EV) in the automobile industry. However, charging of EV battery from the utility grid increases the load demand on the grid and eventually increases the electricity bills to the EV owners which necessitate the use of alternate energy sources.

Due to inexhaustible and pollution free nature of Renewable Energy Sources (RES), it can be used to charge the EV battery. Thus, RES driven electric vehicle can be termed as “green transportation”. Solar is one of the promising renewable energy sources which can be easily tapped to utilize its energy to charge EV battery. Hence, PV array power is used to charge the EV battery in the proposed system with the help of power converter topologies Lithium-ion batteries are widely used in the EV due to its high- power density, high efficiency, light weight and compact size.

Also, these batteries have the capacity of fast charging and long lifecycle with low self-discharge rate. They also have low risk of explosion if it is over charged or short circuited. During charging, these batteries require precise voltage control. Hence, various power electronic converters with voltage controller are used for charging EV battery. Due to the intermittent nature of PV array, there is a need for power converter which is capable of providing constant output voltage irrespective of input voltage to charge the EV battery.

The rise of electric vehicles (EVs) signals a promising shift towards sustainable transportation, offering a solution to combat climate change and reduce reliance

on fossil fuels. However, challenges persist in the charging infrastructure, with conventional stationary charging stations causing significant waiting times for vehicle owners. This hinders the seamless integration of EVs into mainstream transportation systems. To address this issue, our project aims to develop an innovative solution: the Solar Wireless Charging System in Electric Vehicles. By harnessing

Literature Review

- Advanced movable EV charging stations offer smart features like remote monitoring (Wi-Fi/IoT), app control, precise energy tracking (sensors), and safety cutoffs, with high-power portable units (e-mobility like Chempower) acting like mobile fast chargers.

- While standard portable Level 2 chargers (EV Dance, EVgoer) provide convenience for road trips, though some might have slightly snug connectors. Key benefits include flexibility for emergencies, reducing range anxiety, and lower setup cost than fixed stations, with options for DC fast charging or basic Level 1/2 power. Reviews highlight good build quality for portable units, useful app features for tracking, but potential minor issues like connector fit.

Control: Microcontroller-based management, LCD screen, keypad for settings, auto-cutoff for safety.

Examples: Some units (like EV Dance) are fast, portable, and can be used on the go, with good cable performance.

High-Power Mobile Units (DC Fast Charging):

Function: Act like mobile gas stations, offering rapid charging (e.g., 40kW or 20kW dual) for various vehicles.

Ease of Use: Often on wheels, with touchscreens, phone tracking via QR codes.

Standard Portable Chargers (Level 1/2):

Use Case: Great for emergencies or when away from home/work chargers.

Reviews: Often praised for durability, reasonable pricing, and excellent charging performance, despite being basic.

Review Highlights & Considerations:

Portability: Excellent for road trips, occasional use, or locations without fixed infrastructure.

Build & Connectors: Good units have solid, heavy connectors with metal tabs (like ChargePoint), but some portable plugs can be snug.

Software: Apps can offer great insights (energy, cost) but might lack features like dynamic load management in some cases.

Cost-Effectiveness: Lower setup cost than fixed stations, making charging more accessible.

Verdict:

Advanced movable chargers offer crucial flexibility, bridging infrastructure gaps with smart features for monitoring and control, while basic portable units provide essential emergency power, making them valuable additions to EV ownership despite minor potential fit issues.

Methodology

Advanced movable EV charging station methodologies focus on mobile energy storage (MBESS), smart logistics for dispatch, integration with renewables, IoT for remote management (booking, payment, monitoring), and diverse charging tech (V2G, wireless), all aimed at solving range anxiety and infrastructure gaps by delivering power dynamically where needed, optimizing cost, and enhancing grid resilience. Key aspects involve dynamic routing algorithms, battery management systems (BMS), and cloud platforms for real-time service coordination.

Core Methodologies & Technologies

Mobile Energy Storage (MBESS):

Concept: Large battery packs mounted on vans or trailers act as mobile power banks, offering charging in remote areas, emergencies, or peak demand times.

Functionality: Can provide AC/DC charging and even bidirectional (V2G) services, reducing grid stress.

IoT & Smart Control:

Remote Management: Apps/web platforms for booking, payment, real-time status, and location tracking.

Sensors & Microcontrollers: Monitor power delivery, calculate billing, and manage charging parameters (voltage, current).

RFID/NFC: For user authentication and automated billing.

Renewable Integration & Energy Management:

Hybrid Power: Combining solar/wind with battery storage within the mobile unit.

Grid Optimization: Charging during off-peak hours and potentially feeding energy back (V2G) to stabilize the grid.

Smart Dispatch & Logistics:

Algorithms: Dynamic routing to fulfill user requests efficiently, minimizing travel time and maximizing service.

Predictive Analytics: Using data to anticipate demand and pre-position chargers.

Advanced Charging Technologies:

Wireless Charging: Integration of inductive charging for convenience.

Vehicle-to-Grid (V2G): Bi-directional flow for grid support and revenue.

Operational Workflow

Request: EV driver requests charge via app (location, time, power needs).

Dispatch: Central system optimizes & sends nearest available mobile charger.

Connection & Authentication: Driver connects; RFID/app authenticates user.

Charging: Microcontroller manages power flow, sensors track usage, data sent to cloud.

Completion: Session ends (time/energy goal met), payment processed, charger relocates.

Proposed Solution

Advanced movable EV charging solutions involve portable units (like vans or trailers) with integrated batteries, often charged by renewables (solar), using IoT for smart management, app-based booking, and potentially wireless/inductive tech, offering on-demand, flexible charging to combat range anxiety and grid strain, acting as mobile power banks or temporary station replacements during demand spikes

.System Architecture and Key Components

- Advanced movable EV charging stations use a core architecture of Power Delivery (battery storage, converters, grid connection) and Embedded Computing

(EMS, control units, communication) to offer on-demand charging, featuring key components like smart energy management, IoT/Cloud integration, bidirectional charging, user interfaces, and sometimes solar/battery hybrids

Solar Integration: Solar panels and controllers for self-sufficiency.

Offline Functionality: Browser-based storage (IndexedDB) and synchronization for seamless use without constant internet.

Blockchain Payments: Cryptocurrency-based transactions. Functional Features

Block Diagram

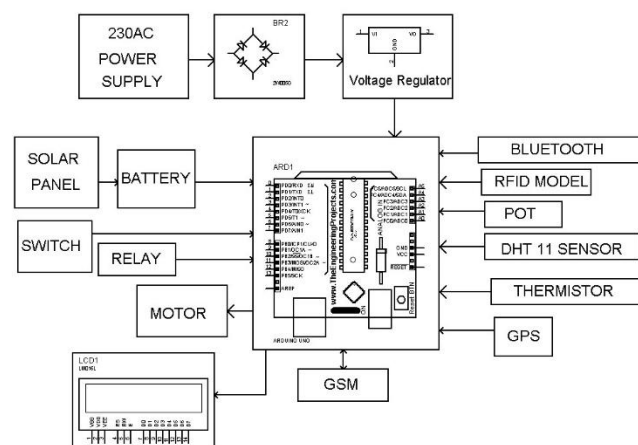

BATTERY

1. The batteries are used as a storage device for solar energy which can be further converted into electrical energy. The only exceptions are isolated sunshine load such as irrigation pumps or drinking water supplies for storage, for small units with output less than one kilowatt. Batteries seem to be the only technically and economically available storage means. Since both the photo-voltaic system and batteries are high in capital costs, it is necessary that the overall system be optimized with respect to available energy and local demand pattern. To be economically attractive the storage of solar electricity requires a battery with following particular combination of properties:

- (1) Low cost
- (2) Long life
- (3) High reliability
- (4) High overall efficiency

6. ich is initially calibrated to individual body parameters.
7. The supervising physician remotely sets the therapy plan on the connected app.
8. Upon initiation, the robot assists the patient through programmed exercises while monitoring vitals continuously.
9. Automated safety checks halt therapy and notify the physician in case of anomalies.

SCHEMATIC DIAGRAM

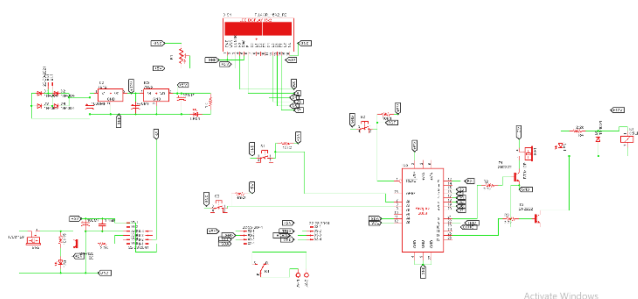

POWER SUPPLY

230V AC supply is given to the step down transformer

The basic building blocks of a regulated DC power supply are as follows:

- A step down transformer
- A rectifier
- A DC filter
- A regulator

Step Down Transformer

A step down transformer will step down the voltage from the ac mains to the required voltage level. The turn's ratio of the transformer is so adjusted such as to obtain the required voltage value. The output of the transformer is given as an input to the rectifier circuit.

APPLICATION

The electric vehicle charging system can also be implement in following places

1. Industry buses
2. Hospitals cars
3. Army four velars

Results

Advanced movable EV charging stations, like mobile energy storage systems (MESSs) and battery swapping, offer flexibility, reduce costs (e.g., 49% savings for taxis), and overcome grid limitations by bringing power to EVs, addressing range anxiety and infrastructure gaps, with technology pushing towards faster, megawatt-level charging, though requiring significant battery management and investment.

Conclusion

The above study effectively demonstrated about the construction of wireless electric vehicle charging system using solar panel. The electric vehicle charging wirelessly reduces the need of transmission wire and reduces the fuel consumption, making it a simple and more practical way. This method reduces the rid of hardware components wear and tear. This advanced moveable charging system can be implementing through dynamic electrical vehicle charging system. Electrical vehicles are the means of transportation of the future because they can maximize the efficiency of charging stations. There will be a major role for electric vehicle charging stations using solar . Increasing EV demand in the market requires addressing the fundamental barrier to EV adoption: a dearth of public charging stations. We looked at the portable EV charger that uses renewable energy to speed up the charging process. The work presented herein presents a novel service to long-distance electric vehicle travelers through the use of a hybrid power system for a vehicle battery charging station. Unfortunately, there is a severe lack of convenient charging infrastructure for drivers of electric vehicles along interstates and highways. The wireless EV charger is the best option for charging their electric automobiles.

The connectivity between the user and the car is based on GSM and GPS . A user can decide the power management by analyzing the status of the battery also he can decide, to provide the excess amount of charge to other applications. The main aim of this project is to minimize the difficulty in building charging stations for electric vehicles. By using above mentioned methods, charging stations can be built easily and can be maintained in a well manner for domestic purposes.

Future Scope

There will be an estimated 15 million plug-in EVs on the road in 2030, 15 times the current amount. A few hundred more fast-charging stations could support painless long-distance travel between U.S. cities.

References

1. . Wireless Power Transfer for Electric Vehicles and Mobile Devices" by Chun T. Rim.
2. "Electric Vehicle Technology Explained" by James Larminie and John Lowry
3. Wireless Power Transfer for Electric Vehicles: Foundations and Design Approach" by Pedro Alou, Miguel Castilla, and Luis G. de Vicuña
4. "Wireless Charging of Electric Vehicles: A Techno-economic Assessment" by Marc Mültin, Florian Schlögl, and Clemens M
5. Pinto, J. G. Bidirectional battery charger with Grid-to-vehicle, Vehicle -to-Grid and Vehicle-to -Home technologies, IEEE 2020"AI-Driven Rehabilitation Robotics," Cureus Journal, 2025. [Online] Available: cureus.com
6. X. Zhou, S. Lukic, S. Bhattacharya, and A. Huang, "Design and control of grid-connected converter in bidirectional battery charger for plug-in hybrid electric vehicle application," in Proc. IEEE Vehicle Power and Propulsion Conference (VPPC), 2019, pp. 1716Bionic Yantra and GenElek Technologies product data, Indian startup ecosystem reports, 2025.
7. –325, 2021, Doi: 10.48175/IJARSCT-1752.