

# IOT Enabled Blue Force Tracking System for Battlefield Awareness

## D. Gowthami

Department of Electronics and  
Communication Engineering  
Annamacharya Institute of  
Technology and Sciences  
Tirupathi, India  
[thangamgowthami@gmail.com](mailto:thangamgowthami@gmail.com)

## Kamatham Pavithra

Department of Electronics and  
Communication Engineering  
Annamacharya Institute of  
Technology and Sciences  
Tirupathi, India  
[kpavithra308@gmail.com](mailto:kpavithra308@gmail.com)

## Thinnuluru Sruthi

Department Of Electronics and  
Communication Engineering  
Annamacharya Institute of  
Technology and Sciences  
Tirupathi, India  
[thinnellurusruthi@gmail.com](mailto:thinnellurusruthi@gmail.com)

## Rekhanderrao Brahma

Department of Electronics and  
Communication Engineering  
Annamacharya Institute of  
Technology and Sciences  
Tirupathi, India  
[brahma0431@gmail.com](mailto:brahma0431@gmail.com)

## Vennapusa Naga

Department of Electronics and  
Communication Engineering  
Annamacharya Institute of  
Technology and Sciences  
Tirupathi, India  
[vennapusanaga3@gmail.com](mailto:vennapusanaga3@gmail.com)

## Mallarapu Puneeth Sankrandan

Department of Electronics and  
Communication Engineering  
Annamacharya Institute of  
Technology and Sciences  
Tirupathi, India  
[puneethsankrandan@gmail.com](mailto:puneethsankrandan@gmail.com)

**Abstract**—Blue Force Tracking(BFT) systems is a real time information of the whereabouts, the health of soldiers and their safety. This paper presents IOT Enabled Blue Force Tracking system that is recommended to enhance the situation awareness on the battlefield and the tactical decision making. In this system is integrated Arduino UNO, movement detection sensors (MEMS), location tracking sensors (GPS), heart rate sensors (MAX30100), long communication(LORA). Wireless communication transmits data to the central command unit. Commanders are also able to keep an eye on the state of the soldier and deal with the emergency situation in a timely manner. The IOT Enabled Blue Force Tracker is a digital tool to support the current defense operations. This system will help to minimize the risk of operation, using the security, distributed and smarter data collection using IOT technologies, to provide precise, real time information to improve the safety of the battlefield.

**Keywords**—IOT, Blue Force Tracking, Arduino UNO, GPS Module, soldier Health Monitoring, Wireless communication, Situational Awareness.

## I. INTRODUCTION

To properly manage the battlefield and assure the safety of troops, troop movements, operational statuses and environmental conditions must be constantly tracked, but traditional Blue Force(BFT) systems are prone to sluggishness and signal jamming and lack sensor integration which reduces their usefulness in dynamic and hostile environments. The implementation of Internet of Things(IoT) is a revolutionary solution of BFT because it provides realtime data authorization, peripheral computation and safe communication between wireless networking.

The system is an IoT-enabled BFT solution to increase the situational awareness and the decision making capabilities of the troops in the field by constantly collecting important data which includes troop location, movement velocity, physiological parameters, and wearable sensor data, *optional* GSM module. Sensor fusion and edge computing make sure that information is handled as data to central command intelligence, whereas secure IoT protocols relay the processed information to a central command server. Warnings about

possible danger, deviations along the road or emergency signals may also be relayed with real-time effectiveness enhancing operational reaction and reducing the number of victims. In the proposed system the focus is low power consumption, resistance to failures in any one node, and strength of the communication system where performance should be continuous under the strenuous conditions of the contemporary battle fields.

## II. . LITERATURE SURVEY

Studies within the context of the Blue Force tracking have been able to develop beyond traditional methods of GPS based tracking gadgets to developed sensor networks with IoT capacity. Initial versions of BFT offered only rudimentary positional information but were wanting in other fields of providing real time information, reliability of information and integration with other systems on the battle field. Recent studies discuss wireless sensor networks and edge computing to overcome these limitations and show enhancements in data accuracy, reduction in latency and flexibility in operations. A number of works point to microcontrollers as Arduino in low cost battlefield tracking applications, as they are versatile, power efficient, and simple to interface with other components such as sensors and communications devices. IoT can be incorporated to provide real time remote monitoring, predictive analytics, automated notifications, and GSM and low power RF modules are used to provide connectivity where there is no traditional internet availability. Security is another major issue of concern, multi-tier encryption, secure weekend route protocol and authentication systems have been suggested in an effort to secure sensitive operational information. It is also indicated in literature that redundancy and fault tolerance is necessary to retain the ability to track the information in case of node failures or signal impeding.

[1] A GPS based soldier tracking System was put forward by Smith et al. The system is primarily employed to do simple surveillance and GPS location tracking.

[2] Kumar and Gupta suggested an Internet of Things Based Solider Health Monitoring System. This is a wearable sensor based system which gathers vital signs like heart rate, temperature and they were relayed to remote monitoring stations.

[3] Lee and Park devised a Real-Time Solider Tracking System with the help of IoT. This system comprises of GPS and accelerator sensors connected to the internet. It gives real-time report of positions of soldiers, enhancing situational awareness on the command level.

[4]A Cloud-Based IoT Framework to monitor Soldiers was created by Sharma et al. This system gives a better

decision making capability where commanders were able to visualize location and health parameters in real time.

[5] Rao and Singh came up with a MEMS Developed Motion Detection Military Wearable. This system also offers a high degree of detection of any motion such as sudden falls, which may be vital to automatic alerts of emergency.

Based on the researches, it is noted that the restricted location tracking, delayed problems, absence of health tracking and insecurity. Hence, the suggested system offers secure data through wireless communication, precise real time data, multi-sensor systems used as wearables.

## III. METHDOLOGY

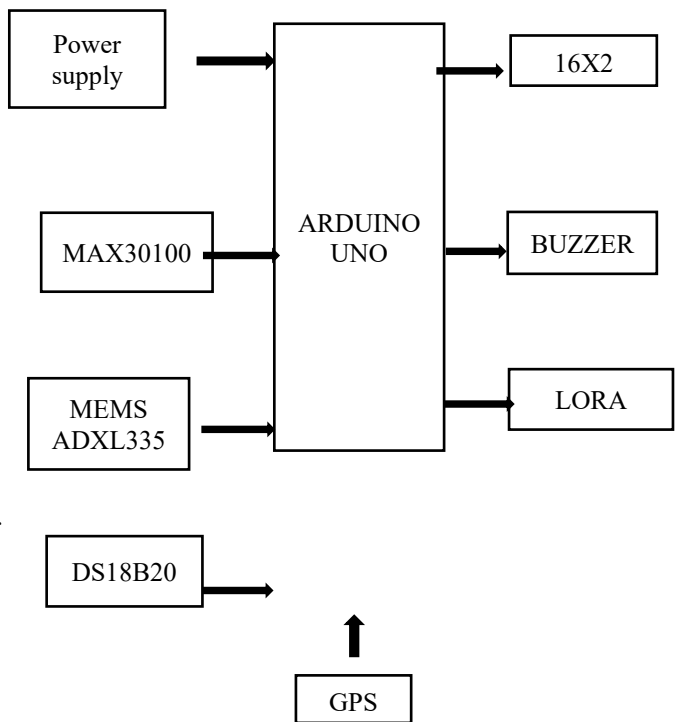

Fig: Block diagram of blue force tracker transmitter

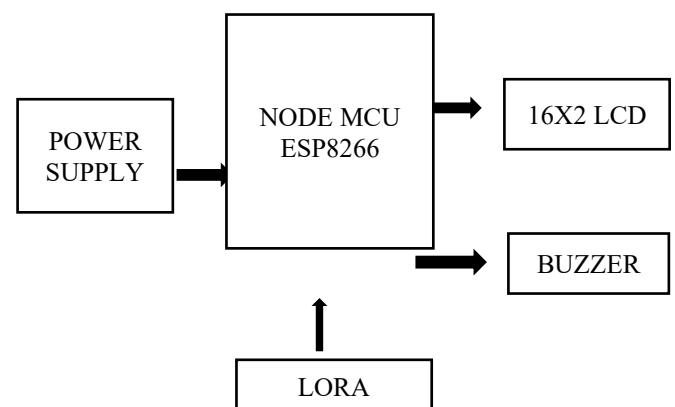

Fig: Block diagram of blue force tracker receiver

## ARDUINO UNO

**Microcontroller:** Microcontroller is a small controller, they are like single chip computers that are often embedded into other systems to function as processing unit. They are also used in automobiles, washing machines, microwaves ovens etc., where automation is needed.

**Arduino Uno Microcontroller:** The Arduino Uno is a microcontroller board based on the Atmega328. It has 14 digital input / output pins, 6 analog inputs, a 16 MHz crystal oscillator, a USB connection, a power jack, an ICSP header and a reset button. It contains everything needed to support the microcontroller, simply connect it to a computer with a USB cable with a AC-to-DC adapter.



Fig.1: Arduino Uno board

**Power Supply:** It can supply all the components with adequate power with the help of a rechargeable battery. It guarantees consistent and constant operation of sensor and low power to increase battery duration.

**MAX30100 Heart Rate Sensor:** MAX30100 is a heart rate sensor which is used to detect the blood oxygen level and heart rate. It is seen to be applied in worn health-surveillance gadgets. MAX30100 has two leds (red and infrared) in order to direct light through the skin. The quantity of light taken in by the blood varies with the heartbeats and level of oxygen. According to this sensor calculates heart rate.

**MEMS ADXL335:** It is a 3-axis MEMS accelerometer that is employed in a 3-axis acceleration and tilt measurement of the X, Y, and Z directions. It is a device that is employed to identify the movement and the level of activity of the soldier. The ADXL335 detects acceleration in mini MEMS structures. Any change in the movement or tilt will have voltage variation at the X, Y, Z output pins.

**DS18B20 Temperature Sensor:** DS18B20 is a digital temperature sensor that is used to measure temperature. It detects temperature and transmits through one wire protocol of the Arduino in a digital form. The IOT module

transfers this data to the Arduino which sends it to the command center.

**Node MCU ESP8266:** Node MCU ESP8266 is a microcontroller that is Wi-Fi based and is commonly used in IOT. It transmits the sensor data wirelessly to the command center. It is fed through processed sensor data on the Arduino and includes itself in WI-FI transmission to the command unit.

**Liquid Crystal Display[16x2]:** A Liquid crystal display is a thin, flat display unit which is comprised of any amount of colour or monochrome pixels arranged over a light source. Real time soldier location, health status and system alerts are shown in the LCD. Processed data are transmitted to the LCD by the microcontroller. It shows significant real time data at the locality in order to use easily.



Fig: LCD Display

**Buzzer:** functions as an alert in case of emergency condition, fall detection and in the need to signal abnormal health conditions. The microcontroller switches on the buzzer when the sensors sense the occurrence of an abnormal state. It creates a sound to give an immediate warning.

**LORA:** LORA is a transmission that will transfer the location of troops, health information in long ranges and requires minimal power that can be used in the wearables. The sensor gets the data of the soldier and transmits it to the microcontroller which in turn transmits it to the lora which transmits them to the receiver over a long distance.

## IV. RESULT AND DISCUSSION



Fig(a).



Fig(b).

Blue Force Tracker system was tested by using above hardware setup. Here fig(a) indicates transmitter section, it collects sensor data and transmitted through the IOT communication module to the monitoring unit. And fig(b) indicates receiver section, the microcontroller continuously acquires data from the connected sensors and displays the real time health parameters like body temperature, heart rate, movement shows on the LCD. The displayed values update continuously, indicating live data acquisition and processing.

## V. CONCLUSION

This paper introduces a new IOT enabled Blue Force Tracking system named WARRIOR intended to offer improved safety, situation awareness and tactical decisions on the part of the soldiers. IOT communication modules and edge processing- by incorporating Arduino Uno microcontrollers, GPS and wearable sensors. WARRIOR defeats the constraints of the conventional BFT systems such as latency, poor data integration and resistance as a consequence of signal disruption. The system will provide close real-time upgrades, high resilience in event of node failures, and better positional accuracy which can greatly minimize the risk of operational events. It can be used in a wide variety of battle field applications due to its modular design, affordability, and IOT compatibility. Advanced autonomous work predictive analytics, as well as the use

of other environmental-sensitive sensors, may be incorporated into the future work to further improve the work efficiency and ensure the safety of the soldiers.

## VI. ACKNOWLEDGMENT

The authors would like to say that they are deeply grateful to ANNAMACHARYA INSTITUTE OF TECHNOLOGY & SCIENCES, TIRUPATHI (Autonomous) to introduce these facilities and assistance to conduct this work. The authors are very grateful to Dr. S. Rohini, M. Tech., Ph.D., Associate Professor and Head of the department of Electronics and Communication Engineering, who has given her all the time to be supportive. D. Gowthami, M. Tech., Assistant professor, Department of ECE is given special credits in the support that he offered in the publication of this paper.

## VII. REFERNCE

- Priyanka Mane, Rajesh Bharatiya, "IOT Enabled Blue Force Tracker: The Warrior System for Enhanced Situational Awareness, " SATC 2025,IEEE.
- S. K. Sharma, R. kumar, "IOT-Based Battlefield Monitoring and Tactical Decision Systems," International Journal of Defense Technology,2023.
- M. Tan, L. Zhao, "Wireless Sensor Networks in Military Applications: Design and Security Challenges," IEEE Access,2022.
- P. Singh, A. Agarwal,"Edge Computing for Real-Time Solider Monitoring and Tracking," Journal of Embedded Systems,2023.
- R. Joshi, V. Reddy, "Arduino-Based Low-Power Tactical Tracking Nodes with IOT Integration," International Conference on Smart Systems,2024.